

Important!

Do not Destroy!

Please Read!

***Herd* SURE-FEED BROADCASTER**

***Herd* MODEL 750**

CAPACITY: 750 LBS., 12 CU. FT., 9.6 BU.

**Instructions For
Assembly, Mounting, Seeding,
Operating and Maintenance.**



***Repair
Parts List***



www.herdseeder.com

HERD SEEDER COMPANY, INC.

PHONE No. 574-753-6311

FAX No. 574-722-4106

P.O. BOX 448

2383 SOUTH U.S. 35

LOGANSPOUT, INDIANA 46947-0448

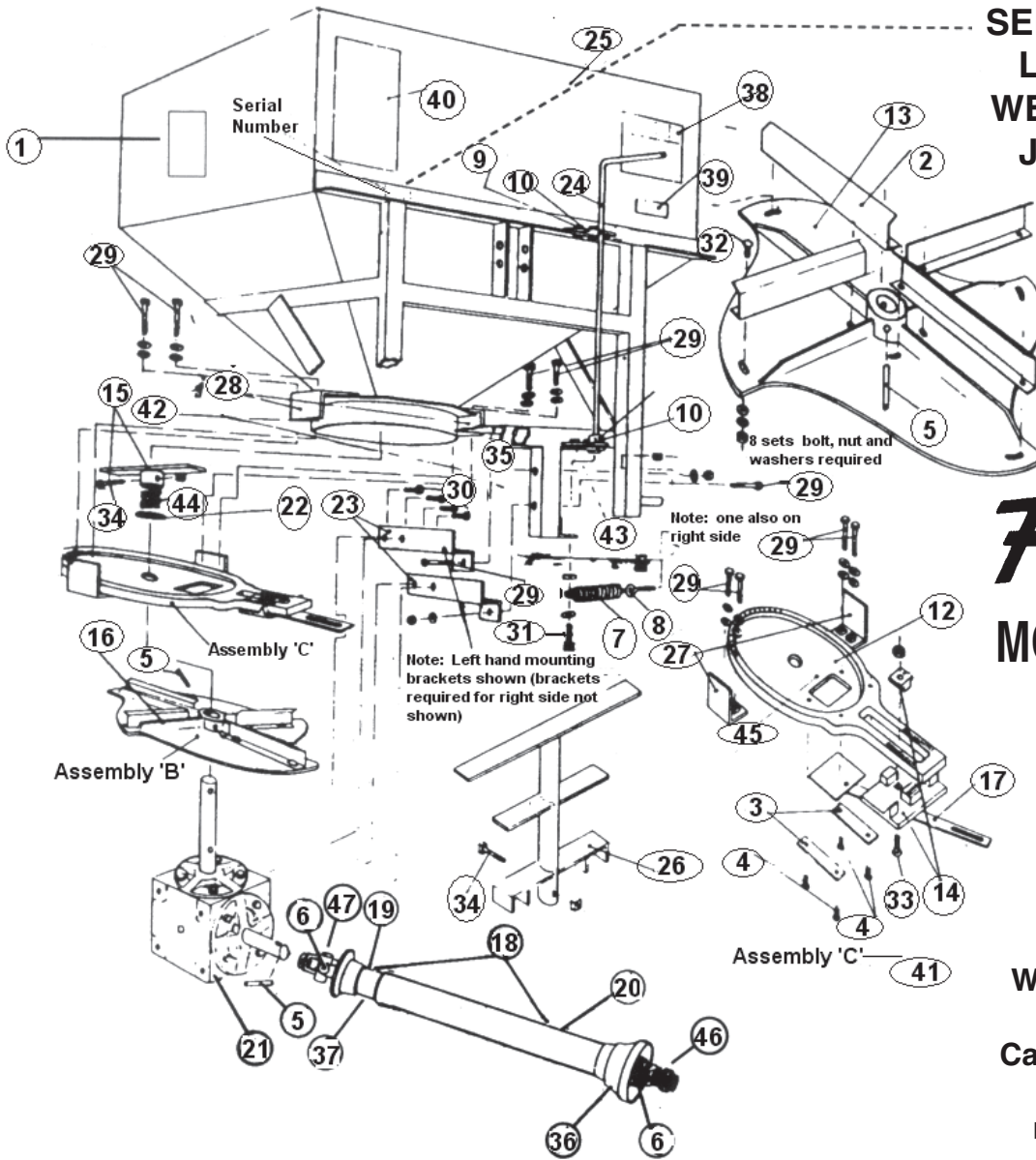

**SERIAL NUMBER
LOCATED ON
WELDED PLATE,
JUST BELOW
MODEL NO.
DECAL**

***Herd*
MODEL 750**

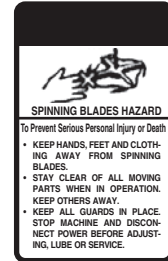

**Warning Decal -
If missing
Call 574/753-6311
for free
replacement.**

CAUTION: KEEP all guards and shields in place at all times. Disengage power take-off and shut off tractor engine before making any adjustments or repairs to seeder. KEEP hands, fingers and loose clothing well away from any and all moving parts at all times.

PARTS FOR MODEL 750 BROADCASTER SHOWN IN PHOTO: (750 LB., 9.6 BU., OR 12 CU. FT. CAPACITY)

(WHEN ORDERING PARTS, BE SURE TO GIVE BOTH MODEL NUMBER AND SERIAL NUMBER. SEE TOP OF PAGE FOR LOCATION OF SERIAL AND MODEL NUMBERS.)

NO.	PART NO.	NAME	NO. REQ.
1.	1091	WARNING SPINNING BLADES DECAL	1
2.	102	BLADES FOR FAN, WITH BOLTS (420)	4
3.	106	SEED GATE GUIDES	2
4.	107	1/4" x 1/2" CAP SCREWS - TO HOLD CONTROL PLATE TO BASE PLATE	4
5.	111	5/16" x 2" SPRING PIN, FOR DRIVEN END OF POWER TAKE-OFF SHAFT AND FAN.....	2
6.	78	REPAIR KIT "W" FOR P.T.O. SHAFT (PIN & BLOCK TYPE) FOR WEASLER P.T.O.....	2
	843	CROSS & BEARING REPAIR KIT (G & G P.T.O. SHAFT).....	2
	79P	NYLON BEARING FOR PLASTIC SHIELD OF WEASLER P.T.O. SHAFT	2
	46	BEARING SHIELD KIT, NYLON BEARING, SNAP RING & THRUST WASHER - FOR G & G	2
	80P	BEARING RETAINER FOR PLASTIC SHIELD OF WEASLER P.T.O. SHAFT	2
7.	116	TENSION SPRING	1
8.	117	EYE-BOLT	1
9.	407	5/16" x 1" BOLT W/NUT & LOCK WASHER.....	1
10.	213	BRACKET FOR CONTROL HANDLE, UPPER & LOWER.....	2
12.	144	HOPPER BASE PLATE	1
13.	145	FAN BASE ONLY (TO WHICH BLADES FASTEN).....	1

14.	146	SEED OPENING GAUGE, WITH BOLT (COMPLETE).....	1
	146B	BOTTOM PART ONLY OF 146 SEED GAUGE	1
	146U	UPPER PART ONLY OF 146 SEED GAUGE	1
15.	147	REGULAR AGITATOR WITH BOLT & NUT	1
16.	148	FAN, COMPLETE WITH SPRING PIN	1
17.	149	OPENING CONTROL PLATE, WITH LINKAGE.....	1
18.	150P*	25-1/4" SHIELDED POWER TAKE-OFF SHAFT FOR 1-3/8" PTO WITH 1" DRIVEN END.....	1
19.	150FP	BROADCASTER END OF 25-1/4" POWER TAKE-OFF SHAFT.....	1
20.	150MP	TRACTOR END OF 25-1/4" POWER TAKE-OFF SHAFT	1
21.	2000	GEAR BOX, COMPLETE - FOR 540 RPM (SEE CUT ON GEAR BOX FOR PARTS) (SAME AS 151)...	1
	2000M	GEAR BOX, COMPLETE - FOR 1,000 RPM (SAME AS 151M) (OPTIONAL)	1
22.	152	WASHER - 1" BORE, USED ON FAN SHAFT IN HOPPER	1
23.	154	"Z" ANGLES USED TO CARRY GEAR BOX - LEFT SIDE	2
	153	"Z" ANGLES USED TO CARRY GEAR BOX - RIGHT SIDE (NOT SHOWN IN DRAWING)	2
24.	212	HANDLE ASSEMBLY FOR 750	1
25.	211	HOPPER FOR MODEL 750 (11-1/2 CU. FT. CAPACITY).....	1
	214	FRAME, LESS CONTROL HANDLE (PRICE ON REQUEST)	
26.	158	LIME AGITATOR W/BOLT, USED WITH DEHYDRATED LIME OR DOLOMITE (OPTIONAL).....	1
27.	159	"L" BASE CLAMP - LOWER.....	2
28.	160	"L" BASE CLAMP - UPPER (WELDED TO HOPPER)	2
29.	418	1/2" x 3" BOLT WITH NUTS AND FLAT WASHERS.....	8
30.	419	3/8" x 1" BOLT WITH LOCK WASHERS.....	8
31.	407A	5/16" x 1" BOLT WITH NUT AND WASHER.....	2
32.	420	5/16" x 3/4" CARRIAGE BOLT WITH NUT AND LOCK WASHER.....	8
33.	421	5/16" x 1-1/4" CARRIAGE BOLT WITH NUT	1
34.	422	5/16" x 1-3/4" BOLT WITH NUT (USED IN AGITATOR 147)	1
35.	1093	DEFLECTOR - 22" LONG (NOT SHOWN IN DRAWING)	1
36.	92P	PLASTIC SHIELD FOR TRACTOR HALF OF WEASLER P.T.O. SHAFT (INCLUDES #79P & 80P)	1
	95	PLASTIC SHIELD FOR TRACTOR HALF OF G & G P.T.O. SHAFT (INCLUDES #46 & 47).....	1
37.	93P	PLASTIC SHIELD FOR SEEDER HALF OF WEASLER P.T.O. SHAFT (INCLUDES #79P & 80P).....	1
	94	PLASTIC SHIELD FOR SEEDER HALF OF G & G P.T.O. SHAFT (INCLUDES #46 & 47)	1
38.	215	FERTILIZER INSTRUCTION DECAL FOR MODEL 750.....	1
39.	216	MODEL NUMBER DECAL - FOR 750.....	1
40.	989C	SEEDING CHART DECAL	1
41.	222	ASSEMBLY "C" COMPLETE, OF BASE PLATE 144 AND PARTS.....	1
42.	223	HOPPER BASE RING (MUST BE WELDED TO HOPPER)	1
43.	86A	5/16" x 1" CAP SCREW WITH 2 NUTS AND FLAT WASHER.....	1
44.	1123	STAINLESS STEEL COMPRESSION SPRING - USED BETWEEN AGITATOR AND WASHER	1
45.	1126	1/4" x 3/8" HEX HEAD CAP SCREW	1
46.	96	YOKE ONLY, FOR TRACTOR HALF OF WEASLER P.T.O. SHAFT.....	1
	101	YOKE ONLY, FOR TRACTOR OF G & G P.T.O. SHAFT	1
47.	97	YOKE ONLY, FOR BROADCASTER HALF OF WEASLER P.T.O. SHAFT	1
	103	YOKE ONLY, FOR BROADCASTER HALF OF G & G P.T.O. SHAFT.....	1

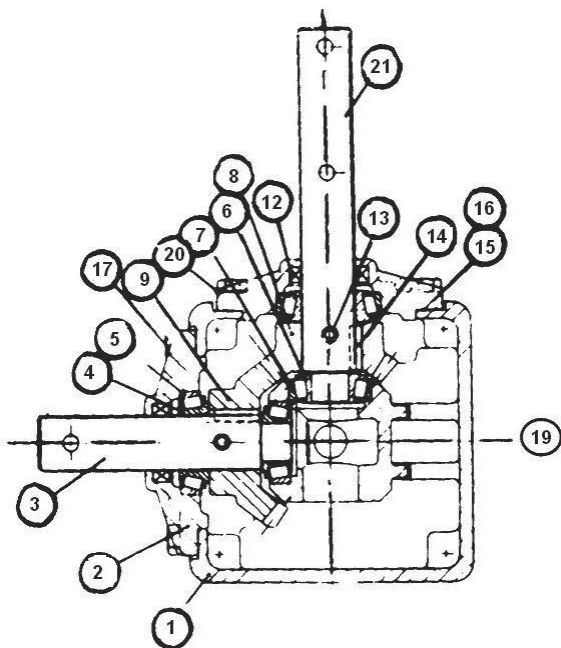

PARTS FOR 2000 (OR 151 GEARBOX WITH 1" SHAFTS:)
FOR MODEL 750

1.	2017	HOUSING.....	1
2.	2016	CAP	2
3.	2018	SHORT SHAFT, DRIVE	1
4.	2013	BEARING CONE - LARGE (L44643)	2
5.	2012	BEARING CUP - LARGE (L44610)	2
6.	2011	BEARING CONE - SMALL (LM11749).....	2
7.	2010	BEARING CUP - SMALL (LM11710).....	2
8.	2014	GEAR, STEEL, 14-TOOTH	1
9.	2019	GEAR, STEEL, 19-TOOTH	1
12.	2009	OIL SEAL.....	2
13.	2005	ROLL PIN	2
14.	2008	KEY.....	2
15.	2006	GASKET - .014	VAR.
16.	2007	GASKET - .005	VAR.
17.	2002	5/16" x 1" HEX HEAD CAP SCREW	8
19.	2003	VENTED PIPE PLUG	1
20.	2001	5/16" LOCK WASHER	8
21.	2015	LONG SHAFT - VERTICAL DRIVEN.....	1
	2020	SHIM.....	VAR.

DESIGNS SUBJECT TO CHANGE WITHOUT NOTICE.

MODEL 750 BROADCASTER

PREPARING FOR USE AND SERVICING:

1. THE GEARBOX IS SHIPPED FROM THE FACTORY WITH ONE PINT OF 90 WEIGHT GEAR LUBRICANT AND BEFORE USING THE BROADCASTER YOU MUST CHECK FOR THE PROPER LEVEL. YOU CAN DO THIS BY REMOVING THE FILL PLUG, PART NUMBER 2003, LOCATED AT NUMBER 19 ON GEARBOX PARTS BREAK-DOWN. THE OIL LEVEL IS SUFFICIENT IF THE OIL IS AT OR JUST BELOW THE PLUG HOLE. IF THE LEVEL IS LOW, FILL THE GEARBOX WITH 90 WEIGHT GEAR LUBRICANT TO PLUG HOLE LEVEL.
2. CUT THE TWO WIRES HOLDING THE POWER TAKE OFF-SHAFT TO THE BROADCASTER FOR SHIPPING. NOW REMOVE THE TAPE FROM THE GEARBOX SHAFT THAT IS USED TO PROTECT IT FROM PAINT AND CLEAN ANY PAINT FROM THE SHAFT. PLACE THE 1" HOLE END OF THE POWER TAKE-OFF SHAFT OVER THE GEARBOX SHAFT AND INSERT THE PART NUMBER (111) 5/16" x 2" SPRING PIN PROVIDED WITH THE POWER TAKE-OFF SHAFT. AS AN EXTRA PRECAUTION, YOU COULD RUN A WIRE THROUGH THE NUMBER 111 SPRING PIN AND AROUND THE HUB OF THE POWER TAKE-OFF SHAFT TO HELP KEEP THE SPRING PIN IN PLACE.
3. **"CAUTION"!** CHECK TO SEE THAT THE P.T.O. SHAFT (PART #150P) IS NOT TOO LONG BEFORE RAISING THE SEEDER WITH THE 3-PT. HITCH. IF IT IS TOO LONG, IT WILL BOTTOM OUT AND CAUSE DAMAGE TO THE GEARBOX. IF THE POWER TAKE-OFF SHAFT IS TOO LONG, YOU WILL NEED TO CUT EQUAL AMOUNTS OFF OF BOTH ENDS OF THE POWER TAKE-OFF SHAFT BEFORE RAISING THE SEEDER ON THE 3-PT. HITCH AND ATTACHING UPPER CENTER LINK ARM TO THE SEEDER.
4. TO ASSEMBLE HANDLE: (SEE FIG. 1)
 - (A) CUT WIRES LOCATED AT TOP AND BOTTOM HOLDING HANDLE AGAINST BROADCASTER IN SHIPMENT.
 - (B) REMOVE NUT ON EYE BOLT. (#117)
 - (C) LOOSEN THE 5/16" x 1" BOLT ON LOWER HANDLE BRACKET. THEN MOVE HANDLE AWAY FROM BROADCASTER AND RETIGHTEN THE 5/16" x 1" BOLT.
 - (D) REMOVE 5/16" x 1" BOLT LOCATED IN ANGLE. USING THIS BOLT, BOLT UPPER HANDLE BRACKET TO ANGLE.
 - (E) TIGHTEN ALL BOLTS TIGHT, MAKING SURE THAT BRACKETS ARE SETTING AT RIGHT ANGLE TO BROADCASTER. REPLACE SPRING TIGHTENER FOR GOOD TENSION. THIS SPRING WORKS WITH HANDLE AND WILL HOLD OPENING GATE IN EITHER OPEN OR CLOSED POSITION.
5. MAKE SURE THAT HANDLE AND OPENING PLATE OPERATE FREELY. OIL OR KEROSENE WILL CUT AWAY ANY EXTRA PAINT THAT MAY HAVE ACCUMULATED.
6. THE UNIT IS NOW READY TO MOUNT ON TRACTOR WITH 3-PT. HITCH.

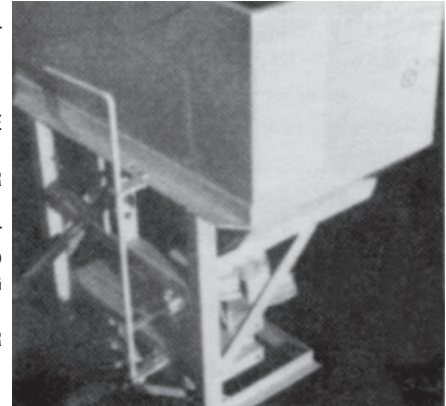

FIG. 1

INSTRUCTIONS FOR MOUNTING ON TRACTOR 3-PT.:

1. LIFT-ARMS SHOULD BE SET FOR NO. 1 CATEGORY, OR 26-7/8" SPACING. SWAY BARS, BLOCKS OR CHAINS MUST BE USED TO KEEP SEEDER FROM SWINGING SIDEWAYS.
2. REMOVE OR MOVE DRAWBAR TO SIDE POSITION SO AS NOT TO INTERFERE WITH POWER TAKE-OFF SHAFT.
3. INSTALL ON TWO LOWER ARMS FIRST, THEN ATTACH POWER TAKE-OFF SHAFT, AND LAST, HOOK UP CENTER ARM.
4. **CAUTION:** WHEN RAISING THE SEEDER FOR THE FIRST TIME, **MAKE SURE THE POWER TAKE-OFF SHAFT DOES NOT BOTTOM OUT**, OR THAT POWER TAKE-OFF SHAFT IS LONGER THAN THE DISTANCE BETWEEN TRACTOR AND SEEDER. IF IT DOES BOTTOM OUT, IT WILL CAUSE THE GEARBOX TO BREAK AND WILL DAMAGE THE FAN. IF POWER TAKE-OFF SHAFT IS TOO LONG, CUT OFF EQUAL AMOUNTS ON EACH END OF BOTH THE MALE AND FEMALE ENDS.
5. RAISE SEEDER UP SO THE POWER TAKE-OFF SHAFT RUNS FAIRLY STRAIGHT OR LEVEL. FOR BEST RESULTS, CENTER LINKAGE SHOULD BE SHORTENED UNTIL BROADCASTER TOP TILTS A LITTLE FORWARD TOWARD TRACTOR.

CENTERING THE SPREAD PATTERN OF SEEDER

1. YOU DETERMINE THE RIGHT OR LEFT OF THE SEEDER BY STANDING AT THE REAR OF THE TRACTOR AND FACING THE DIRECTION OF THE TRACTOR'S TRAVEL.
2. THE MODEL 750 HAS A CIRCULAR PLATE (PART #144) BOLTED TO THE BASE OF THE HOPPER THAT IS ADJUSTABLE, FOR CENTERING THE SPREAD PATTERN. THIS PLATE IS NUMBERED FROM 1 TO 9 AND THE NUMBERS ARE FOUND ON THE BACK SIDE, ON THE OPPOSITE SIDE FROM THE SEED OPENING GAUGE. (PART #146) (SEE FIGURE #2) TO MOVE THE ADJUSTABLE PLATE, LOOSEN THE FOUR BOLTS (PART #418). ALWAYS BE SURE TO RETIGHTEN THE BOLTS AFTER ADJUSTMENTS ARE MADE TO THE PLATE. THE NORMAL SETTING FOR FERTILIZER IS ON NUMBER 3-1/2 (SEE FIGURE #2), AND MAY BE MOVED TO A HIGHER OR LOWER NUMBER, DEPENDING UPON THE WEIGHT AND QUALITY OF THE FERTILIZER BEING SPREAD. **"CAUTION"!** DO NOT MAKE ANY ADJUSTMENTS WHILE SEEDER OR TRACTOR ARE RUNNING.
3. WHEN THE SPREAD PATTERN IS HEAVY ON THE RIGHT SIDE, MOVE THE BASE PLATE (PART #144) TO THE RIGHT, OR CLOCKWISE TO A HIGHER NUMBER. DO NOT MOVE OVER ONE NUMBER BEFORE CHECKING OR YOU MAY OVER COMPENSATE.
4. WHEN THE SPREAD PATTERN IS HEAVY ON THE LEFT SIDE, MOVE THE BASE PLATE (PART #144) TO THE LEFT, OR COUNTERCLOCKWISE, TO A LOWER NUMBER. DO NOT MOVE OVER ONE NUMBER BEFORE CHECKING OR YOU MAY OVER COMPENSATE.
5. MAKE SURE THAT THE BOLTS (PART #418) ARE TIGHTENED EVENLY AFTER MAKING ADJUSTMENTS.

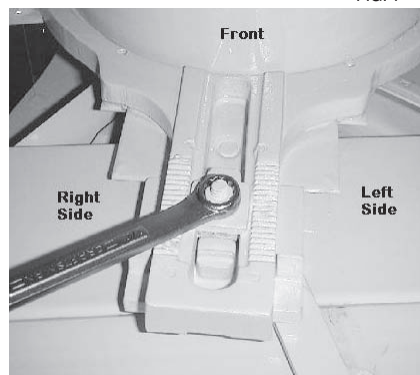

FIG. 1

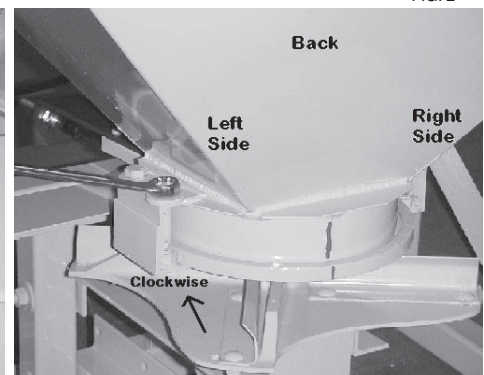

FIG. 2

SEED-GATE OPENING CONTROL:

1. THE WIDTH OF THE SEED-GATE OPENING IS CONTROLLED BY THE SEED GAUGE (PART #146) WHICH IS BOLTED TO THE CIRCULAR PLATE (PART #144) AND THE SEED GAUGE IS MARKED IN 1/8" MARKINGS FOR YOUR CONVENIENCE. (SEE FIGURE #1) IF THE SEED GAUGE MOVED BACK 1/2" FROM 0, THE SEED-GATE OPENING WILL LIKewise OPEN 1/2". A GOOD WAY TO CHECK THE SEED-GATE OPENING FOR ACCURACY IS TO INSERT A DRILL BIT OF THE DESIRE FRACTION OF AN INCH BETWEEN THE SEED-GATE AND THE EDGE OF THE BASE PLATE (PART #144) DOWN INSIDE THE HOPPER. FOR EXAMPLE, A 1/8" DRILL BIT PLACED BETWEEN THE SEED-GATE AND THE BASE PLATE EDGE SHOULD CORRESPOND TO THE FIRST MARK SETTING ON THE SEED GAUGE.
2. THE HANDLE ASSEMBLY (PART #212) IS SPRING-LOADED WITH AN OVER-CENTER DESIGN AND WHEN PUSHED, IT WILL CLOSE THE SEED-GATE AND WHEN PULLED IT WILL OPEN THE SEED-GATE. THE DOUBLE NUTTED BOLT THAT ATTACHES THE HANDLE ASSEMBLY TO THE SEED-GATE LINKAGE SHOULD NOT BE TIGHTENED BECAUSE IT MUST MOVE FREELY IN THE SEED-GATE LINKAGE SLOT TO WORK PROPERLY.
3. WHEN BROADCASTING SMALL SEED AT SMALL AMOUNTS PER ACRE, YOU CAN ORDER THE OPTIONAL SPECIAL SEED-GATE TO GET TO FINER AMOUNTS. THE PART NUMBER FOR THIS SEED GATE IS 149S AND IT HAS TEETH BUILT ON THE EDGE TO RESTRICT THE SEED FLOW AND CONTROL THE FLOW TO MUCH SMALLER AMOUNTS. CALL THE FACTORY FOR MORE INFORMATION AT 574-753-6311.

PARTS AND KITS AVAILABLE BUT NOT SHOWN (FOR MODEL 750)

217	BRACKETS TO CONVERT CATEGORY 1 TO CATEGORY 2	1	pr.
270	ALL FIVE DECALS FOR MODEL 750.....	1	
206	LARGE "HERD SEEDER" DECAL	1	
844	KIT OF PARTS TO MOUNT 750 SEEDER TO EITHER #268 REGULAR OR #269 ORCHARD TRAILERS.....	1	
268	REGULAR TRAILER W/45" PTO SHAFT, TWO 15" WHEELS (NO TIRES) REQUIRES #844 KIT.....	1	
269	ORCHARD TRAILER W/45" PTO SHAFT, WITH TWO LOW-PROFILE WHEELS & TIRES, REQUIRES #844.....	1	
1099	LID ADAPTER KIT FOR 835 LID-REQUIRED WHEN 1090 MINI-HOPPER IS INSTALLED.....	1	
1090	MINI-HOPPER (1-1/2 BUSHEL) FOR CLOVER & ALFALFA SEEDS (HAS SEPARATE CONTROLS)	1	
835	LID COMPLETE (2 PCS.) FOR 750 836 - LEFT SIDE OF LID W/HANDLE		
	837 - RIGHT SIDE OF LID W/HANDLE		

SPECIAL OPTIONS FOR ORCHARD AND VINEYARD SPREADING

1. BANDING KITS MAY BE ORDERED FOR "NO CENTER" SPREADING. THEY MAY BE SET TO SPREAD ON EITHER SIDE OR BOTH SIDES AT THE SAME TIME. THE BANDING KIT PATTERN CAN BE ADJUSTED TO APPLY FERTILIZER FROM AS WIDE AS 34 FEET DOWN TO AS NARROW AS 60 INCHES. INSTRUCTION SUPPLIED WITH KITS.
 - A. PART #180 MANUAL BANDING KIT USES THE EXISTING CONTROL HANDLE ASSEMBLY (PART #212) TO OPEN THE SEED GATES TO FLOW THE FERTILIZER ONTO THE FAN, WHILE BANDING THE FERTILIZER TO EACH SIDE.
 - B. PART #225 HYDRAULIC CONTROLLED BANDING KIT IS AVAILABLE AND USES TWO PUSH-PULL CABLES CONTROLLED BY A HYDRAULIC CYLINDER (NOT PROVIDED) TO OPEN TWO SEPARATE SEED GATES TO FLOW FERTILIZER ONTO THE FAN. REQUIRES EITHER A 1000 KIT OR A 232 KIT TO COMPLETE INSTALLATION.
 - C. PART #225 MANUAL USES TWO SEPARATE LEVERS TO PUSH-PULL TWO SEPARATE CABLES WHICH OPENS OR CLOSES TWO SEPARATE SEED GATES TO FLOW FERTILIZER ONTO THE FAN. DOES NOT REQUIRE ANY ADDITIONAL KITS.
 - D. PART #276 LEFT SIDE ONLY BANDING KIT IS A LESS EXPENSIVE KIT THAT WILL BAND FERTILIZER TO THE LEFT SIDE ONLY. THIS KIT USES THE EXISTING #144 BASE PLATE AND THE #212 CONTROL HANDLE.
SIDE PATTERNS ARE ALSO AVAILABLE:
 - E. PART #82 KIT IS AVAILABLE TO TURN THE PATTERN TO ONE SIDE (EITHER RIGHT OR LEFT) WITH ALL OVER PATTERN ON ONE SIDE.
 - F. PART #838 SIDE-PATTERN KIT CAN BE ORDERED IF THE SEEDER HAS A #1000 KIT INSTALLED.

FOR SPREADING DOLOMITE OR DEHYDRATED LIME: Not Wet Ag Lime!

1. PART #158 LIME AGITATOR MUST BE INSTALLED.
2. WIDTH OF SPREAD WILL BE ABOUT 14 FEET.
3. UNDER NORMAL CONDITIONS, 1200 LBS. OF DOLOMITE OR DEHYDRATED LIME WILL GO THROUGH A 1" SEED-GATE OPENING IN 6 MINUTES.
4. FILL THE HOPPER IN THE FIELD ONLY: DO NOT DRIVE ANY EXTRA OR UNNECESSARY DISTANCE OR THE LIME WILL PACK IN THE HOPPER AND NOT ALLOW IT TO FEED TO THE FAN.
5. DO NOT LEAVE ANY LIME IN THE HOPPER OVER NIGHT OR AN EXTENDED PERIOD OF TIME OR IT WILL PACK AND NOT FLOW OUT OF THE HOPPER TO THE FAN.
6. RUN THE TRACTOR P.T.O. AT 540 R.P.M. THE TRACTOR MAY BE RUN SLOWER ONLY TO KEEP THE DUST DOWN. HOWEVER, DO NOT RUN THE P.T.O. UNDER 300 R.P.M. AT ANY TIME OR THE LIME WILL PLUG AND NOT FLOW THROUGH THE OPENING.
7. ENGAGE THE TRACTOR P.T.O. SLOWLY WITH THE LIME AGITATOR INSTALLED OR YOU WILL SHEAR THE BOLT (PART #422) THAT CONNECTS THE LIME AGITATOR TO THE GEARBOX.
8. DO NOT USE THE #158 LIME AGITATOR FOR SPREADING FERTILIZER OR SEEDS. WHEN SPREADING FERTILIZER OR SEED BE SURE TO REPLACE THE #158 LIME AGITATOR WITH THE STANDARD #147 AGITATOR.

SEEDING CHART

SEED	OPEN WIDTH	WIDTH OF SPREAD	POUNDS PER ACRE - SPEED IN M.P.H.					
			5 M.P.H.	6 M.P.H.	7 M.P.H.	8 M.P.H.	9 M.P.H.	10 M.P.H.
ALFALFA	1/8"	28 FT.	12 LBS.	10.8 LBS.	9.6 LBS.	8.4 LBS.	7.2 LBS.	6 LBS.
BLUE GRASS	1/2"	18 FT.	16	14.4	12.8	11.2	9.6	8
BROME GRASS	1/4"	10 FT.	7	6.3	5.6	4.9	4.2	3.5
CLOVER	1/8"	28 FT.	12	10.8	9.6	8.4	7.2	6
HAIRY VETCH	1/4"	40 FT.	33	29.7	26.4	23.1	19.8	16.5
HULLED LESPEDEZA	1/8"	36 FT.	13	11.7	10.4	9.1	7.8	6.5
MEADOW FESCUE	1/4"	18 FT.	13.5	12.2	10.8	9.4	8.1	6.8
OATS	1/2"	33 FT.	86	77.4	68.8	60.2	51.6	43
ORCHARD GRASS	1/4"	12 FT.	12	10.8	9.6	8.4	7.2	6
PIPER SUNDAN - SWEET	1/4"	36 FT.	32	28.8	25.6	22.4	19.2	16
RICE	1/2"	33 FT.	180	162	144	126	108	90
RYE GRASS	1/4"	18 FT.	13.5	12.2	10.8	9.4	8.1	6.8
RYE	1/2"	34 FT.	132	118.8	105.6	92.4	79.2	66
SOYBEANS	3/4"	40 FT.	120	108	96	84	72	60
WHEAT	1/2"	34 FT.	132	108	105	92	79	66

(1 LB. - 0.45 KG 1 MILE - 1.6 KM 1 FOOT - 30 CM)
 (8 LBS. - 3.6 KG 4 MILE - 6.4 KM 12 FEET - 3.6 M)
 (14 LBS. - 6.3 KG 6 MILE - 9.6 KM 18 FEET - 5.4 M)

MAINTENANCE:

1. BEFORE STORING THE MODEL 750, IT SHOULD BE WASHED OUT THOROUGHLY WITH WATER, MAKE SURE THAT ALL FERTILIZER RESIDUE IS REMOVED. FOR CLEANING AT THE BASE OF THE HOPPER AND TO CLEAN THE BASE PLATE #144, LOOSEN THE BOLT (PART #418) THAT HOLDS THE #144 BASE TO THE BOTTOM OF THE HOPPER, SO THERE IS SUFFICIENT SPACE TO WASH OUT ALL CORROSIVE MATERIAL. WHEN THE PARTS ARE DRY, OIL THEM THOROUGHLY, RETIGHTEN THE #418 BOLT WHEN FINISHED.
2. WE ALSO RECOMMEND THAT YOU SEPARATE THE TRACTOR END OF THE P.T.O. SHAFT (PART #150MP) FROM THE SEEDER END OF THE PTO SHAFT (PART #150FP) AND GREASE THEM THOROUGHLY FOR STORAGE. LEAVE THE TWO SECTIONS OF THE PTO SHAFT SEPARATE DURING STORAGE TO PREVENT THEM FROM SEIZING.

TROUBLE-SHOOTING TIPS:

1. IF THE SPREAD PATTERN IS NOT AS WIDE FOR YOUR SEEDING AS WHAT IS SHOWN ON THE SEED OR FERTILIZER CHART FOR A GIVEN SEED, CHECK TO MAKE SURE ONE OF THE SPRING PINS #111 IS NOT SHEARED.
2. OTHER CAUSES OF POOR SPREAD PATTERN:
 - A. BENT OR BROKEN FAN (#145) OR FAN BLADES (#102).
 - B. FAN BLADES (#102) MOVED FROM FACTORY SETTING. (BLADES SHOULD BE IN THE LINE WITH LONG MARKS ON FAN.)
 - C. THE DISTANCE BETWEEN THE FAN (#148) AND THE BASE (#144) SHOULD NEVER BE FARTHER THAN 2-5/16" OR CLOSER THAN 2-5/32", OR IT WILL AFFECT THE SPREAD PATTERN.
 - D. DO NOT RUN THE TRACTOR P.T.O. SPEED OVER 560 R.P.M. BECAUSE TOO MUCH SPEED CAN CAUSE THE SPREAD PATTERN TO BE UNEVEN.
 - E. DO NOT RUN THE TRACTOR P.T.O. SPEED BELOW 530 R.P.M. OR IT WILL RESULT IN A NARROW SPREAD PATTERN.
3. THE MODEL 750 BROADCASTER SHOULD RUN LEVEL OR TILTED SLIGHTLY FORWARD TOWARD THE TRACTOR. ALSO MAKE SURE THAT ONE SIDE OF THE SEEDER IS NOT LOWER THAN THE OTHER.
4. IF THE SPREAD PATTERN IS TOO HEAVY TO THE RIGHT SIDE, MOVE THE #144 BASE PLATE TO A HIGHER NUMBER AND IF THE SPREAD PATTERN IS TOO HEAVY TO THE LEFT SIDE, MOVE THE #144 BASE PLATE TO A LOWER NUMBER.
5. WHEN THE MATERIAL BEING SPREAD DOES NOT FEED EVENLY:
 - A. CHECK THE MATERIAL TO SEE IF ANY FOREIGN MATTER IS IN THE HOPPER AND BLOCKING THE OPENING OR SEED-GATE #149.
 - B. CHECK TO SEE THAT THE AGITATOR #147 IS BENT DOWN CLOSE TO THE BASE PLATE #144 BUT DO NOT BEND IT SO MUCH THAT THE AGITATOR STRIKES THE BASE PLATE WHEN ROTATING.
 - C. CHECK TO SEE THAT THE OPENING IS NOT SET TOO CLOSE FOR THE SIZE OF MATERIAL BEING SPREAD. TO OVERCOME THIS, SET THE OPENING LARGER AND DRIVE FASTER OR ORDER PART #149S WHICH IS A SPECIAL SEED-GATE WITH TEETH ON ITS EDGE TO RESTRICT THE FLOW OF SEED AND ALLOW THE SEED-GATE TO BE OPENED WIDER.
 - D. DO NOT RUN THE FAN FOR ANY LENGTH OF TIME WITH THE OPENING GATE (#149) CLOSED, OR THE AGITATOR WILL GRIND UP THE MATERIAL AND PACK OVER THE OPENING GATE...CAUSING POOR FEEDING OF THE MATERIAL. YOU CAN OVER-AGITATE THE MATERIAL IF YOU ARE NOT CAREFUL.
 - E. IF YOU NEED TO CONVERT THE 750 FROM A 540 R.P.M. GEARBOX TO A 1,000 R.P.M. GEARBOX TO GO ON A 1,000 R.P.M. TRACTOR P.T.O. PLEASE CALL THE FACTORY FOR MORE INFORMATION AT: 574-753-6311.